

# PRO Series >>>

## Horizontal Arm Type CNC 3D Coordinate Measuring Machines

# PRO Compact/Select/Premium

Ideal for measurement of car bodies, sheet metal, etc.

- The “PRO” Series of CNC 3D coordinate measuring machines is ideal for error analysis and process control in car body measurement.
- Lineup of three types, Compact/Select/Premium, to meet various user requirements
  - PRO Compact Highly cost-effective, low-priced type
  - PRO Select Faster, higher precision upgraded type
  - PRO Premium High-end model. Stepless 2-axis rotating probe holder: DSE (provided as standard)  
Non-contact line laser sensor “EagleEye” can be mounted.
- An outstanding design concept frees you from the need to remodel the machine structure, and allows you to upgrade from the Compact to the Select and to the Premium.
- Contact sensors are provided on the probe holder and side of the Y-axis arm as a collision safety interlock.
- Linear guides are used as the drive system to ensure improved rigidity and higher speed and accuracy.

Premium



Compact



Select

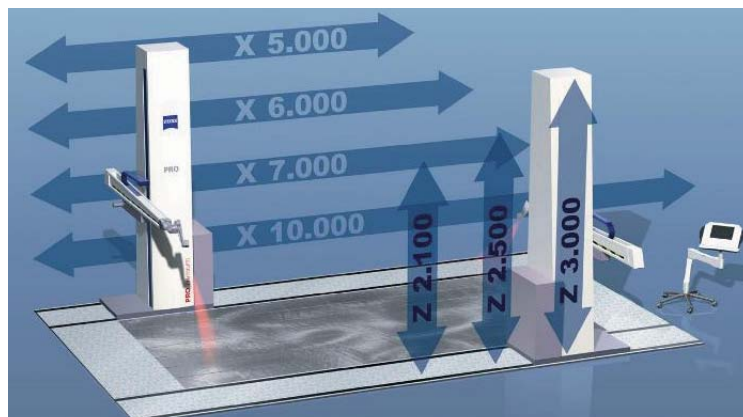

● **Size/Variation**

X-axis: 5000, 6000, 7000, 10000mm  
 Y-axis: 1600mm  
 Z-axis: 2100, 2500, 3000mm

● **Accuracy Upgrades**

Base-ACC: Compact standard  
 Enhanced-ACC: Select/Premium standard  
 High-ACC: High precision specification option

3D Coordinate Measuring Machines

## ■ Features of PRO+EagleEye

### ● Multi-sensor Interface (MSI)

Rotating probe holder DSE, RDS and contact/non-contact sensors can be exchanged.

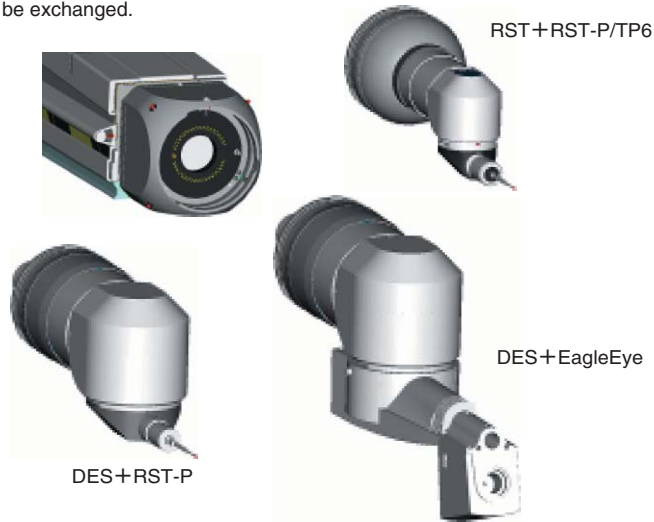

### ● Stepless 2-axis rotating probe holder: DES05/III

Angle of rotation A, B-axes  $\pm 180^\circ$   
 Resolution 0.5"  
 Rotation speed 40°/s  
 Positioning repeatability  $\pm 3''$   
 (provided as standard on PRO Premium)



### ● Non-contact Line Laser Sensor: EagleEye

Wide measuring range 33x71x104mm  
 Standard measuring range 116mm  
 Angle of rotation C-axis  $\pm 180^\circ$  (6th axis)  
 Production site temperatures Precision guaranteed from 16°C to 40°C  
 High-speed measurement Max. 23,000 points per second  
 Semiconductor laser specifications Class 2M

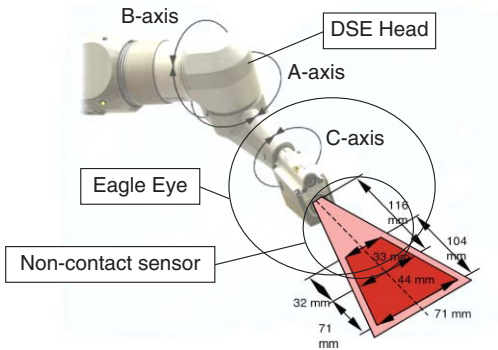

### ● 6-axis control sensor system

(DSE+EagleEye)  
 6-axis control is mandatory for car body measurement.  
 Five axes are not enough for measurement inside "white bodies".

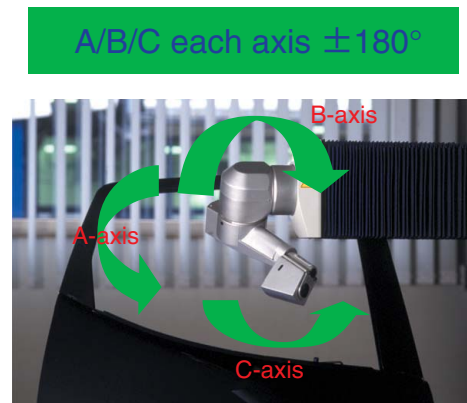

### ● Example of measurement inside car body

To improve measurement probability, cross measurement is sometimes performed by operating only the C-axis (EagleEye tip rotating section). This measurement is a difficult operation to perform on other manufacturers' machines.

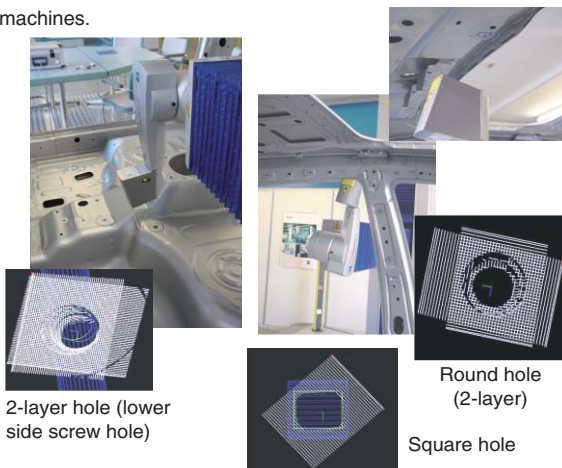

**6-axis control + line laser sensor** considerably improve productivity. The following elements can also be measured: Edge points, round holes, oblong holes, square holes, tubes, 2-layer holes, ultra-small holes, spheres, patch surfaces (free curved surfaces), flashes and gaps, and screw holes

**The total measurement time is shortened by -30 to -50% or more!**

(compared with conventional contact measurement)

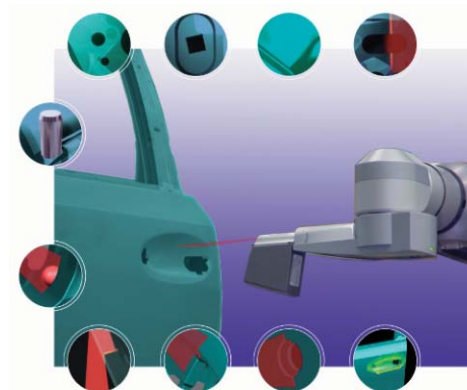

● **Software**

**CMM-OS and HOLOS enable measurement to be easily performed.**

Automatic element calculations

- Element detection
- Element calculation
- Point group analysis
- Free curved surface measurement/analysis

Offline teaching

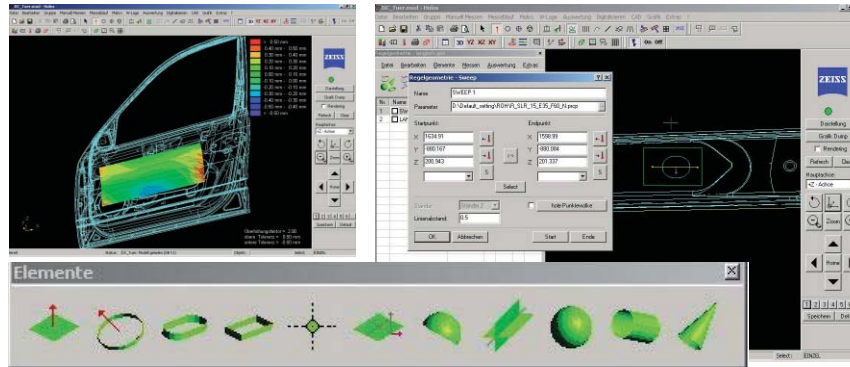

● **Dynalog-P operation panel**

This operation has an integrated LCD monitor and keyboard, which means that all measurement operations can be performed away from a PC.



● **Servo lift**

(operation panel stand)



● **Probe Exchange Magazine (option)**

This magazine allows the RST-P probe and EagleEye to be automatically exchanged.



● **Safety Interlock: Light Barrier System (option)**

(with 2 corner mirrors attached)

Shutting off the entry of light decreases the travel speed of the measuring machine by about one third.

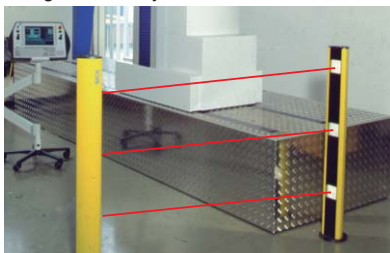

● **Probe Collision Sensor**

The contact comes loose immediately when the probe holder collides with the workpiece to immediately stop the measuring machine.



● **Y-axis Arm Collision Sensor**

This tape sensor is attached to the center on the side of the Y-axis arm to sense the pressure of a collision and immediately stop the measuring machine.

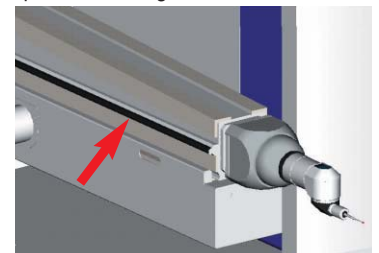

● **2-axis Rotating Probe Holder: RDS-CAA**

Provided as standard on Compact and Select



● **Touch Sensor: TP6**

Provided as standard on Compact



● **Touch Sensor: RST-P**

Provided as standard on Select and Premium



## PRO External View

Single Column

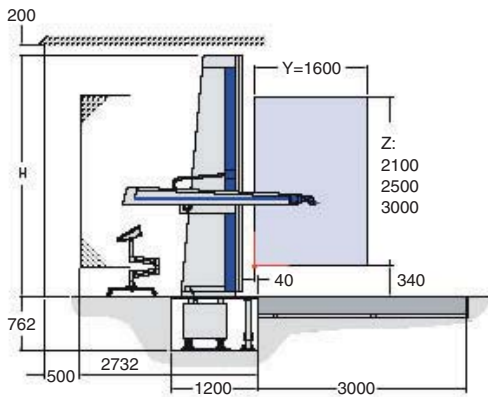

Double Column

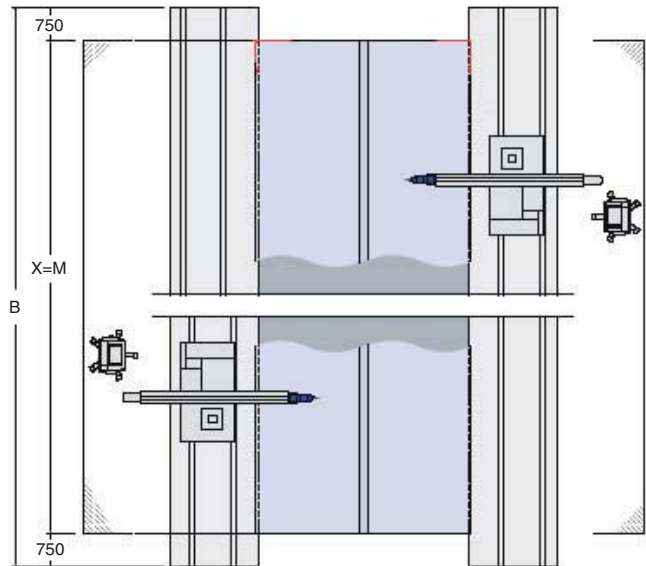
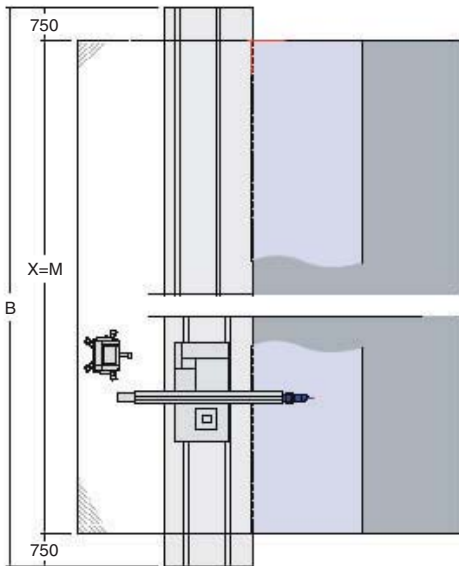
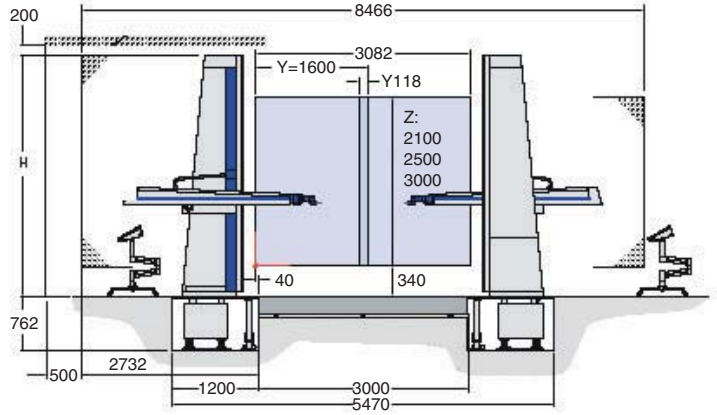

X stroke (mm) X	Measuring Level		X Guide Beam	
	Length (mm) M	Weight (kg)	Length (mm) B	Weight (kg)
5000	5000	11550	6500	3250
6000	6000	13900	7500	3750
7000	7000	16200	8500	4250
10000	10000	23100	11500	5750

Z stroke (mm) Z	Z Column	
	Height (mm) H	Weight (kg)
2100	3045	500
2500	3445	550
3000	3945	600

## Specifications

Model		PRO		
Measuring Range (mm)	X	5000, 6000, 7000, 10000		
	Y	1600		
	Z	2100	2500	3000
Type		PRO Premium		
Measuring Accuracy	Maximum Permissible Indication Error	MPE_E ( $\mu\text{m}$ )	$25 + L/100 \leq 60$	$35 + L/80 \leq 90$
	Maximum Permissible Probing Error	MPE_EM ( $\mu\text{m}$ )	$40 + L/70 \leq 90$	$50 + L/55 \leq 130$
		MPE_P ( $\mu\text{m}$ )	20	30
Temperature Conditions	Ambient Temperature ( $^{\circ}\text{C}$ )	16 to 24 $^{\circ}\text{C}$		
	Temperature Change	1.5 $^{\circ}\text{C}/\text{hour}$ , 3.0 $^{\circ}\text{C}/\text{day}$ , 1.0 $^{\circ}\text{C}/\text{m}$		
Type		PRO Select		
Measuring Accuracy	Maximum Permissible Indication Error	MPE_E ( $\mu\text{m}$ )	$25 + L/100 \leq 60$	$35 + L/80 \leq 90$
	Maximum Permissible Probing Error	MPE_EM ( $\mu\text{m}$ )	$40 + L/70 \leq 90$	$50 + L/55 \leq 130$
		MPE_P ( $\mu\text{m}$ )	20	30
Temperature Conditions	Ambient Temperature ( $^{\circ}\text{C}$ )	16 to 24 $^{\circ}\text{C}$		
	Temperature Change	1.5 $^{\circ}\text{C}/\text{hour}$ , 3.0 $^{\circ}\text{C}/\text{day}$ , 1.0 $^{\circ}\text{C}/\text{m}$		
Type		PRO Compact		
Measuring Accuracy	Maximum Permissible Indication Error	MPE_E ( $\mu\text{m}$ )	$30 + L/70 \leq 80$	$55 + L/50 \leq 120$
	Maximum Permissible Probing Error	MPE_EM ( $\mu\text{m}$ )	$40 + L/50 \leq 100$	$68 + L/35 \leq 180$
		MPE_P ( $\mu\text{m}$ )	25	35
Temperature Conditions	Ambient Temperature ( $^{\circ}\text{C}$ )	16 to 24 $^{\circ}\text{C}$		
	Temperature Change	1.5 $^{\circ}\text{C}/\text{hour}$ , 3.0 $^{\circ}\text{C}/\text{day}$ , 1.0 $^{\circ}\text{C}/\text{m}$		
Type		High Precision Specifications (Option)		
Measuring Accuracy	Maximum Permissible Indication Error	MPE_E ( $\mu\text{m}$ )	$18 + L/125 \leq 50$	—
	Maximum Permissible Probing Error	MPE_EM ( $\mu\text{m}$ )	$30 + L/80 \leq 75$	
		MPE_P ( $\mu\text{m}$ )	15	
Temperature Conditions	Ambient Temperature ( $^{\circ}\text{C}$ )	18 to 22 $^{\circ}\text{C}$		
	Temperature Change	0.5 $^{\circ}\text{C}/\text{hour}$ , 2.0 $^{\circ}\text{C}/\text{day}$ , 0.3 $^{\circ}\text{C}/\text{m}$ high		
Controller		C99		
Operation Panel		DYNALOG-P (with operation panel stand)		
Software		CMM-OS, HOLOS		
Rotating Probe Holder	Compact	RDS-CAA		
	Select	RDS-CAA		
	Premium	DSE 05/III		
Probe Head	Compact	Standard: TP6 (option: RST-P)		
	Select	Standard: RST-P (option: TP6)		
	Premium	Standard: RST-P (option: EagleEye)		
Measuring Scale		Steel scale		
Scale Resolution ( $\mu\text{m}$ )		1.0		
Guide System		Linear guide		
Drive Speed (mm/s) each axis direction	Compact	150 max.		
	Select	150 max. with safety light barrier: 500 max.		
	Premium	150 max. with safety light barrier: 500 max.		
Drive Acceleration (mm/s <sup>2</sup> )		1000 max.		
Air Source	Supply Pressure	0.6 to 1.0 MPa		
	Usage Pressure	0.5 MPa		
	Air Consumption Volume	Single column: 60 NR/hour, Double column: 2×60 NR/hour		
Power Requirements	Supply Voltage	Single-phase 100V $\pm$ 10%		
	Frequency	50/60 Hz $\pm$ 3.5%		
	Max. Power Consumption	Single column: 2500 VA, Double column: 2×2500 VA		

\* MPE\_E (Maximum Permissible Indication Error) and MPE\_P (Maximum Permissible Probing Error) are based on the ISO 10360-2-2001 (JIS B 7440-2-2003) evaluation method for 3D coordinate measuring machines.

\* The above accuracies apply when a standard stylus is used. L (mm) is any measurement distance.

\* Measurement accuracy MPE\_EM is the maximum permissible indicator error for a double column.