

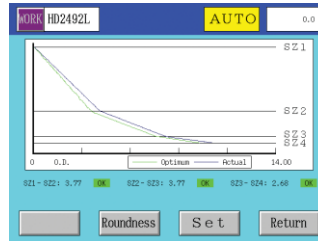

PULCOM V10

In-Process · Post-Process Indicator Control Units



Machining status display

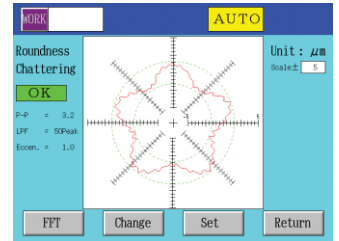

Roundness display

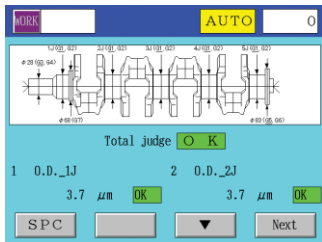

Workpiece diagram/
Measuring result display

NO.	Meas. item	Calculate	Data	Grd.
1	O.D._1J	G1+G2	-0.7 μm	OK
2	O.D._2J	G1+G2	-0.9 μm	OK
3	O.D._3J	G1+G2	-0.9 μm	OK
4	O.D._4J	G1+G2	-0.7 μm	OK
5	O.D._5J	G1+G2	-0.5 μm	OK
6	Runout_1J	G1	2.5 μm	OK
7	Runout_2J	G1	2.7 μm	OK
8	Runout_3J	G1	1.8 μm	OK

Measuring item display

1	2	3	4
6.5	-0.5	7.5	6.5
+OK	OK	+OK	+OK
5	2.5	3.3	2.7
OK	OK	OK	OK

Measuring result display

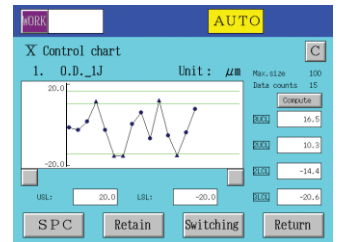

SPC display

Machine Control Gauges

Features

Intelligent Judgment Control

SPC control (post process) and display and output of ellipticity, chattering judgment and machining status (in-process) provide high added value.

Multipoint Measurement

Hardware that allows connection of a maximum of 4 judgment heads and software that permits a maximum of 32 items to be measured provide the optimum configuration for simultaneous parallel processing.

Dramatically Enhanced Operational Ease

A 6.4 inch bright TFT color LCD with a touch panel has been adopted for the display unit. This dramatically enhances operational ease. Simply touch the screen you wish to set or change when making adjustments or performing other operations.

Many More Display Functions

Real-time graphic display for in-process judgment enables machining status to be determined at a glance, simplifying discovery of problems (signal can be optionally output in the event of a problem). The machining status can be replicated when a defective workpiece is discovered in a subsequent process, simplifying analysis of the cause of the defect. For post-process judgment, the display can be tailored to the functions used (e.g. overall display of all judgment items and statistical processing display).

Compatible with PULCOM U2000A

Standard provision of an I/O port provides compatibility with the U2000A (excluding some special models).

Meter Display

Machining status can be displayed on the LCD for in-process measurement, providing a realistic view of machining conditions.

More Standard Functions

The V10 has a variety of standard functions, including auto mastering, operational expression input, smoothing and extended range display/high resolution.

Overall Data Display

Display of a workpiece diagram, judgment items and judgment results on a single screen facilitates judgment of the current status.

Multi-Language Capability

Results can be displayed in English or Japanese.

Size Shift Function for Multi-Product Lines (Option)

Combing this unit with an extended range measuring head enable judgment of multiple axis workpieces without changing the setup. A maximum of 1,280 size shift settings can be registered.

In-Line Roundness (Option)

Roundness can be measured during or after machining. Roundness results are displayed as polar coordinates and output as an OK or NG judgment. The provision of an FFT analysis function facilitates judgment of chattering and a regular diameter distorted circle, too.

Specifications

Model	E - PV 10
Display	6.4" TFT color LCD
Display items	Measured results, list of items (meter display for in-process)
Display range	Changeover between $\pm 50\mu\text{m}$, $\pm 100\mu\text{m}$, $\pm 250\mu\text{m}$, $\pm 500\mu\text{m}$, $\pm 1000\mu\text{m}$, $\pm 2500\mu\text{m}$ and $\pm 5000\mu\text{m}$
Resolution	0.01 μm , 0.05 μm , 0.1 μm , 0.5 μm , 1 μm
Display unit	Select μm , mm or inch
No. of detectors	4
No. of measured items	Max. 32
Input method	Touch panel/shift key
Judgment output	Standard: I/O1 (I/O3 when insufficient)
Multiplication calibration	Key input
Sampling speed	1ms or less (Option: 200 μs)
RS-232C	Standard
Printer output	Standard
Changing of program	Key operation after PC card is input
Remote operation	From handy terminal (option)
Memory function	Option
Waterproof standard	IP54
CE marking	Individual
Outer dimensions	298(W) \times 315(D) \times 159(H) mm (mounting dimensions same as U2000A)

Optional Functions

- In-line roundness function
- BCD/binary input/output function
- RS232C input/output function
- Memory function (Max., min., point-to-point values)
- Workpiece diagram display function
- In-process machining status display (with defective machining, excessive machining time and output functions)
- Temperature compensation
- External zeroing
- Size shift function
- Auto calibration
- Abbreviated wiring
- Analog output function
- P100 (Integral) function

Main Optional Units

- Thermal printer compatible with graphic functions
- Handy terminal
- Temperature sensor
- PC card

Outer Appearance/Dimension Diagram

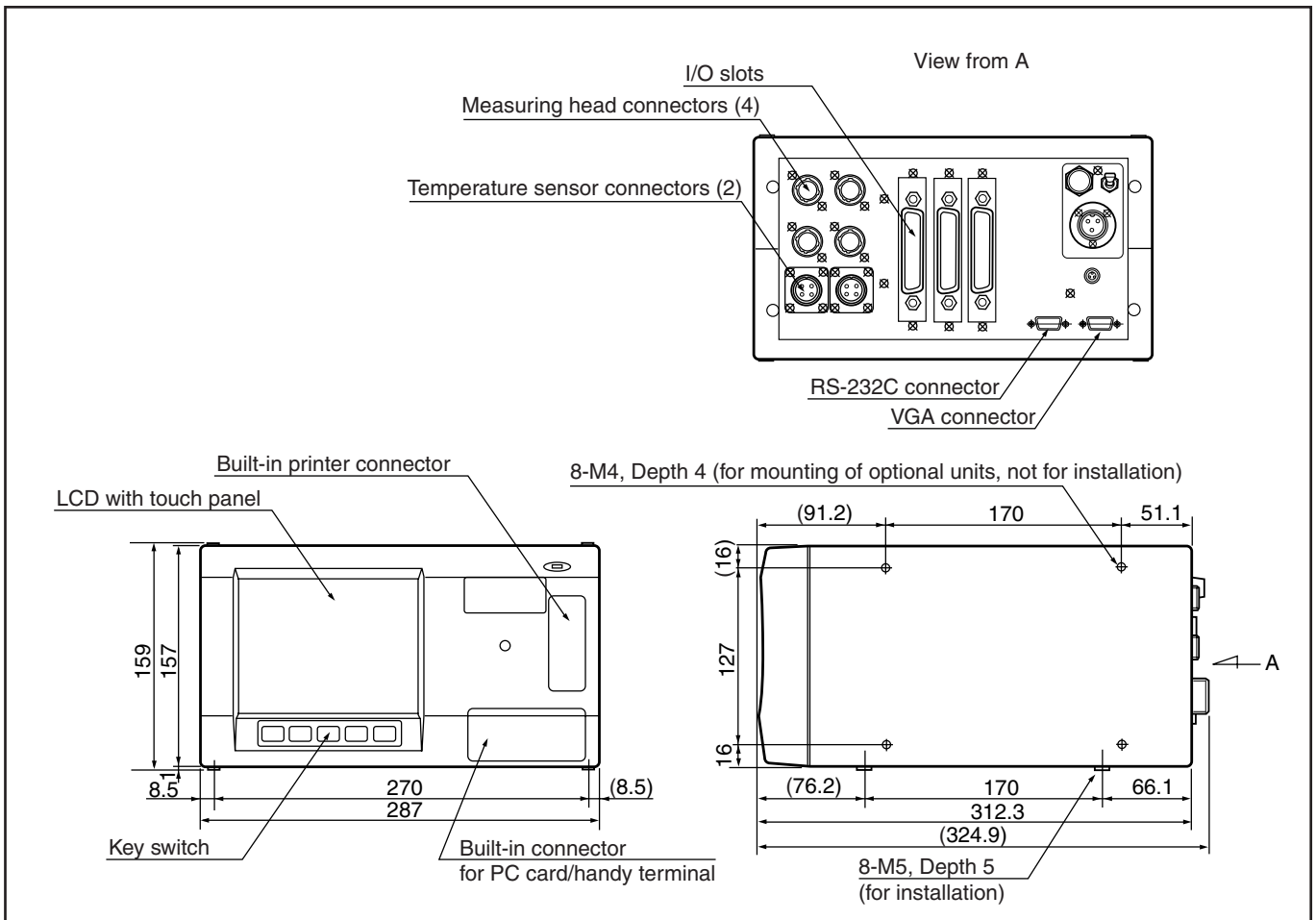

I/O-1 Input/Output Signals

Standard port for basic functions

- (1) Connector: 57E-30500-D76 (50P, made by DDK)
- (2) Cable: Provided with 6m shielded wire cable, outer diameter ϕ 12.4
- (3) Output specifications: Select open collector or open drain
- (4) Pin arrangement

Output			
Signal name	No.	ID	
(*1) Meas. 1	-NG	1 Pink 1	
		OK3 2 Pink 2	
		OK2 3 Pink 3	
		OK1 4 Pink 4	
		+NG 5 Pink 5	
	+NG	6 Pink 6	
		Meas. 2	-NG 7 Pink 7
			OK3 8 Pink 8
			OK2 9 Pink 9
			OK1 10 Pink 10
Meas. 2	-NG	11 Yellow 1	
		OK3 12 Yellow 2	
		OK2 13 Yellow 3	
		OK1 14 Yellow 4	
		+NG 15 Yellow 5	
	+NG	16 Yellow 6	
		OK3 17 Yellow 7	
		Meas. 4	OK2 18 Yellow 8
			OK1 19 Yellow 9
		+NG 20 Yellow 10	
Overall OK output	21 Green 1		
Overall NG output	22 Green 2		
Auto master complete output	23 Green 3		
Auto master NG	24 Green 4		
Meas. prep. complete output (READY)	25 Green 5		
Retract OK	26 Green 6		
All judgment complete output	27 Green 7		
Judgment complete output	28 Green 8		
CPU Run	29 Green 9		
	30 Green 10		
All auto master complete output	31 Gray 1		
N.C.	32 Gray 2		
Output signal common terminal (COMMON)	33 Gray 3		

Input		
Signal name	No.	ID
Individual judgment Gr. 1 start	34	Gray 4
Individual judgment Gr. 2 start	35	Gray 5
Individual judgment Gr. 3 start	36	Gray 6
Individual judgment Gr. 4 start	37	Gray 7
Individual judgment Gr. 1 reset	38	Gray 8
Individual judgment Gr. 2 reset	39	Gray 9
Individual judgment Gr. 3 reset	40	Gray 10
Individual judgment Gr. 4 reset	41	White 1
Auto master Gr. 1 command	42	White 2
Auto master Gr. 2 command	43	White 3
Auto master Gr. 3 command	44	White 4
Auto master Gr. 4 command	45	White 5
	46	White 6
	47	White 7
	48	White 8
	49	White 9
	50	White 10
Input common terminal (COMMON)		

- Make sure to ground the shielded wiring.
- Do not connect any terminals to the empty items.
- Input signal: 10mA or less per signal.
- Output signal: Use at DC24V, 40mA or less.

(*1) Example of a sizing instrument with post.
(*2) Example of 4 items of post

* The above is an ordinary example. The relationship between the signals and pin numbers may change depending upon the specifications.

I/O-2 Input/Output Signals (Optional)

Expansion port for BCD/binary data output

- (1) Connector: 57E-30360-D76 (36P, made by DDK)
- (2) Cable: Provided with 6m shielded wire cable, outer diameter ϕ 10.8
- (3) Output specifications: Select open collector, open emitter or open drain
- (4) Pin arrangement

Output		
Signal name	No.	ID
BCD output 1×10^n	1	Pink 1
BCD output 2×10^n	2	Pink 2
BCD output 4×10^n	3	Pink 3
BCD output 8×10^n	4	Pink 4
BCD output $1 \times 10^{n+1}$	5	Pink 5
BCD output $2 \times 10^{n+1}$	6	Pink 6
BCD output $4 \times 10^{n+1}$	7	Pink 7
BCD output $8 \times 10^{n+1}$	8	Pink 8
BCD output $1 \times 10^{n+2}$	9	Pink 9
BCD output $2 \times 10^{n+2}$	10	Pink 10
BCD output $4 \times 10^{n+2}$	11	Yellow 1
BCD output $8 \times 10^{n+2}$	12	Yellow 2
	13	Yellow 3
Over	14	Yellow 4
"-" polarity	15	Yellow 5
Data valid	16	Yellow 6
Output signal common terminal (COMMON)	17	Yellow 7

Input		
Signal name	No.	ID
Measurement 1 request	18	Yellow 8
Measurement 2 request	19	Yellow 9
Measurement 3 request	20	Yellow 10
Measurement 4 request	21	Green 1
	22	Green 2
	23	Green 3
	24	Green 4
	25	Green 5
Input common terminal (COMMON)	26	Green 6
Data accept	27	Green 7
N.C.	28	Green 8
N.C.	29	Green 9
N.C.	30	Green 10
N.C.	31	Gray 1
N.C.	32	Gray 2
N.C.	33	Gray 3
N.C.	34	Gray 4
N.C.	35	Gray 5
N.C.	36	Gray 6

- Make sure to ground the shielded wiring.
- Do not connect any terminals to the empty items.
- Input signal: 10mA or less per signal.
- Output signal: Use at DC24V, 40mA or less.

Measuring item resolution μ m	Over signal μ m
0.01	10.00 or more
0.05	10.00 or more
0.1	100.00 or more
0.1	100.00 or more
1	1000 or more

* The above is an example for BCD output specifications. The relationship between the signals and pin numbers may change depending upon the specifications.

I/O-3 Input/Output Signals (Optional)

Expansion port for optional function control signals

- (1) Connector: 57E-30360-D76 (36P, made by DDK)
- (2) Cable: Provided with 6m shielded wire cable, outer diameter ϕ 10.8
- (3) Output specifications: Select open collector or open drain
- (4) Pin arrangement

Output		
Signal name	No.	ID
Workpiece select input (BCD 4×10^1)	1	Pink 1
Workpiece select input No. 1 or (BCD 1×10^0)	2	Pink 2
Workpiece select input No. 3 or (BCD 4×10^0)	3	Pink 3
Workpiece select input No. 4 or (BCD 8×10^0)	4	Pink 4
Workpiece select input No. 5 or (BCD 1×10^1)	5	Pink 5
Workpiece select input No. 6 or (BCD 2×10^1)	6	Pink 6
Measurement 1 memory reset	7	Pink 7
Measurement 2 memory reset	8	Pink 8
Measurement 3 memory reset	9	Pink 9
Measurement 4 memory reset	10	Pink 10
	11	Yellow 1
	12	Yellow 2
	13	Yellow 3
	14	Yellow 4
Measurement 1 external synchronize	15	Yellow 5
Measurement 2 external synchronize	16	Yellow 6
Measurement 3 external synchronize	17	Yellow 7
Measurement 4 external synchronize	18	Yellow 8
	19	Yellow 9
Workpiece select input No. 2 or (BCD 2×10^0)	20	Yellow 10
N.C.	21	Green 1
N.C.	22	Green 2
N.C.	23	Green 3
N.C.	24	Green 4
Input common terminal (COMMON)	25	Green 5

Input		
Signal name	No.	ID
Measurement 4 workpiece pass	26	Green 6
Measurement 3 workpiece pass	27	Green 7
Measurement 2 workpiece pass	28	Green 8
Measurement 1 workpiece pass	29	Green 9
	30	Green 10
	31	Gray 1
	32	Gray 2
	33	Gray 3
N.C.	34	Gray 4
N.C.	35	Gray 5
Output signal common terminal (COMMON)	36	Gray 6

- Make sure to ground the shielded wiring.
- Do not connect any terminals to the empty items.
- Input signal: 10mA or less per signal.
- Output signal: Use at DC24V, 40mA or less.

* The above is an example when the optional workpiece change and memory function are provided. The relationship between the signals and pin numbers may change depending upon the specifications.

I/O Cable Identification

(Common for I/O-1, I/O-2 and I/O-3)

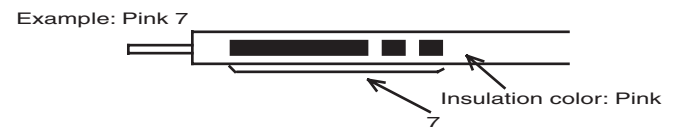

Power Source

- (1) Power source voltage: AC85 - 250V
- (2) Power consumption: 50VA Max.
- (3) Connector: HS16P-3 (made by Hirose Electric)
- (4) Cable: Provided with 6m 3-wire cabtyre, Outer diameter ϕ 8.4mm

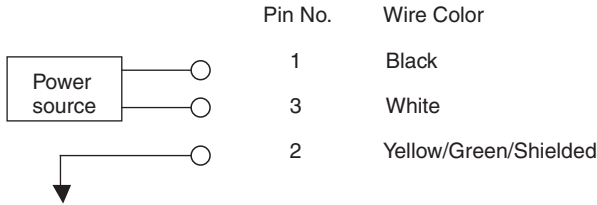

RS-232C Communication Functions (options)

- (1) Connector: D-sub 9-pin connector (male), inch threads
- (2) Communication specifications

Communication standard	Complies with EIA, RS-232C, JIS-C6361
Communication method	All duplex
Synchronization	Asynchronous
DTE/DCE classification	DTE
Transmission code	ASCII
Data bit length	7 or 8 bits
Stop bit length	1 or 2 bits
Parity check	Even, odd, none
Baud rate (bps)	150, 300, 600, 1200, 2400, 4800, 9600, 19200

- (3) Allocation of pin numbers and signals

Pin No.	Signal name	Signal direction	Outline
1	(NC)	-	Not used
2	RD	Input	Receive data
3	TD	Output	Transmit data
4	DTR	Output	Data terminal ready (Turned On when power goes On)
5	GND	-	Signal ground
6	DSR	Input	Data set ready (Operation can be performed when On)
7	RTS	Output	Request to send (Turned On when power goes On)
8	CTS	Input	Can transmit (Operation can be performed when On)
9	(NC)	-	Not used

RS-232C Cable (optional)

- (1) Cable: AWG#28 twisted pair braided shield, UL2464
- (2) Connector: Control unit side: 9-wire male (#4-40 inch)
External device side: 25-wire male (M2.6 mm)
- (3) Connection diagram

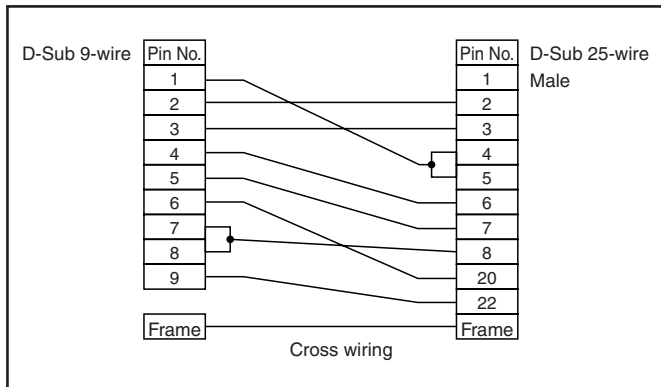

* The RS-232C cable is not included in the RS-232C communication option. If required, please separately order.

PULCOM V11 Detector Expansion Unit (Option)

Specifications

Model	E-PV11
Max. No. of detectors	4
No. of connectable V10	Max. 7 units
Input/output signals	High-speed serial transmission (11 Mbps)
Connection distance	100m
Ambient usage temperature	0 - 40°C
Ambient usage humidity	90% or less (no condensation)
Size shift function	Option
CE marking	Independently provided
Outer appearance	63(W) × 325(D) × 158(H) mm
Weight	3 kg

- (1) Power Source
Voltage: DC24V \pm 10%
Power consumption: 12W
Current consumption: 0.5A or less
Connector: FGG.OB.303.CLAD42 (LEMO), V11 side
Cable: Provided with 6m 2-wire shielded cable, outer diameter ϕ 3.8mm
Shielded wire: Provided with ground wire

Signal	Pin No.	Wire Color	Remarks
+24 V	1	Orange	Conductor: 12 wires/0.18 mm
COM	2	White	
	3	N.C.	

- Note 1: Adequate measures have been taken against noise in this product, but a dedicated power source and noise filter should be used to maximize system reliability.
- Note 2: A power output is provided to enable power to be supplied to a separate V11. Power can be supplied to a maximum of 4 units from one dedicated power supply.

- (2) High-Speed Serial Output
Connector: TM20P-66P module plug (Hirose)
Cable: Provided with 0.5m twisted pair cable, outer diameter ϕ 4.8mm
- (3) Outer Appearance Diagram

