

# Flex Finger (patent pending)

## Flexible Finger for PULCOM Σ

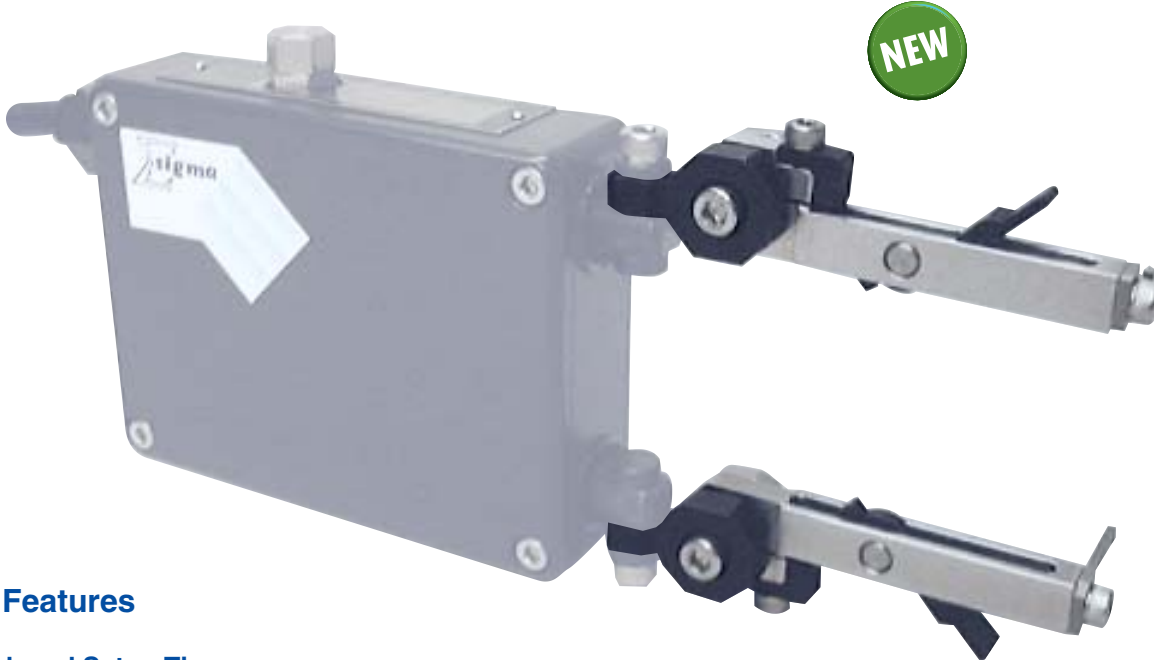

Machine Control Gauges

### ■ Features

#### Reduced Setup Time

Evaluations by users indicate this unit reduces setup changing time from three minutes to one minute. This enables users who are reluctant to perform gauge setup to use the unit.

#### Compact and Compatible

The Flex finger only occupies 37% of the space of the flexible Σ, and retro-fitting can be performed to replace the flexible Σ with certain restrictions.

#### High Precision

This unit can be used with the Super Σ with the same level of precision.

#### Complete Lineup

Inner diameter, outer diameter and space-saving tool types are available.

#### Differences in diameter up to 40 mm can be accommodated

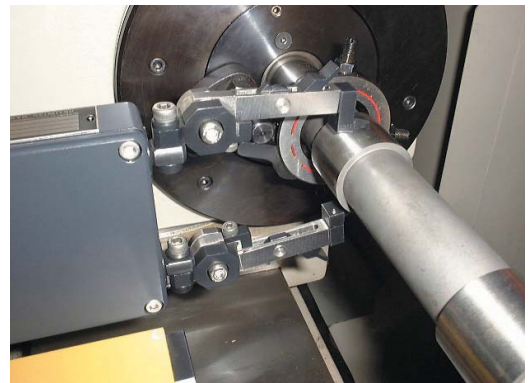

Outer diameter type

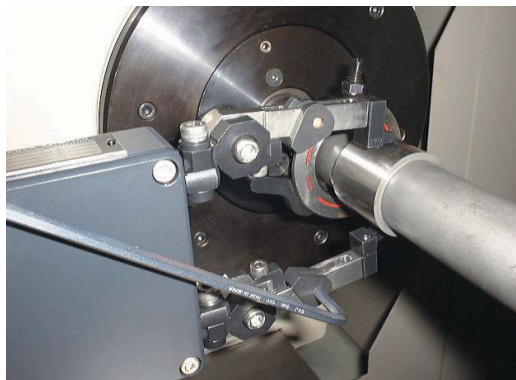

Tool type (inner/outer diameter)



Inner diameter type

## Outer Appearance/Dimension Diagram

A071427-D002-00 (Outer diameter type)

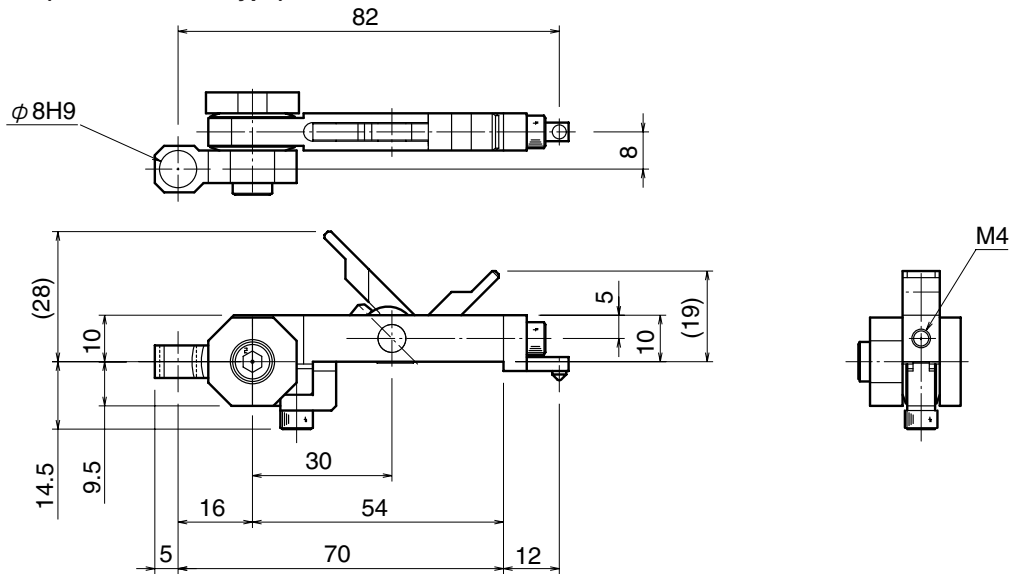

A071428-D002-00 (Inner diameter type)

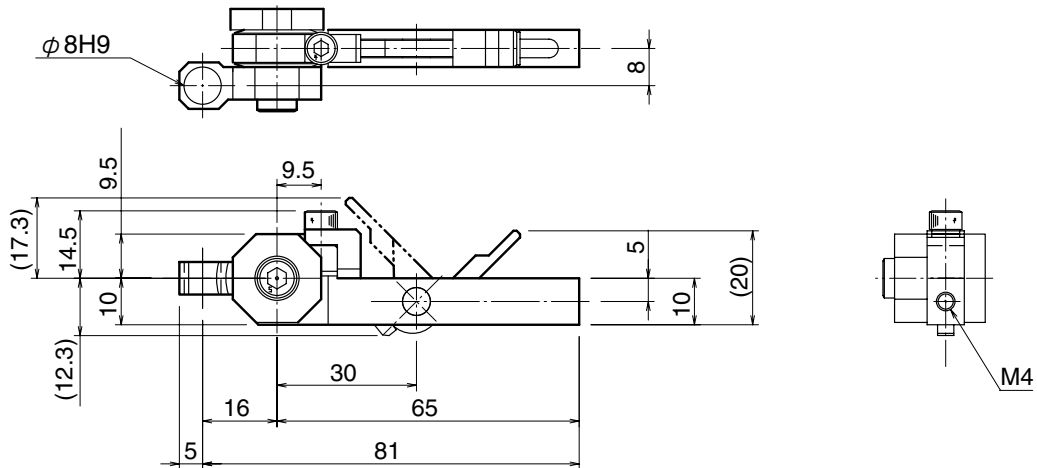

A071427-D003-00 (Tool type – Outer diameter)

A071428-D003-00 (Tool type – Inner diameter)

