

RONDCOM 54DX3

All-in-one Space-saving Configuration

More efficient measuring room operations due to the reduced footprint by about 25% (compared with previous ACCRETECH models).

- Compact, High-accuracy CNC Roundness Measuring Machine
- Rotation accuracy $0.02+3.7H/10,000\mu\text{m}$
- New measurement style with new concept Integrated Analysis Software ACCTee



RONDCOM 54DX3

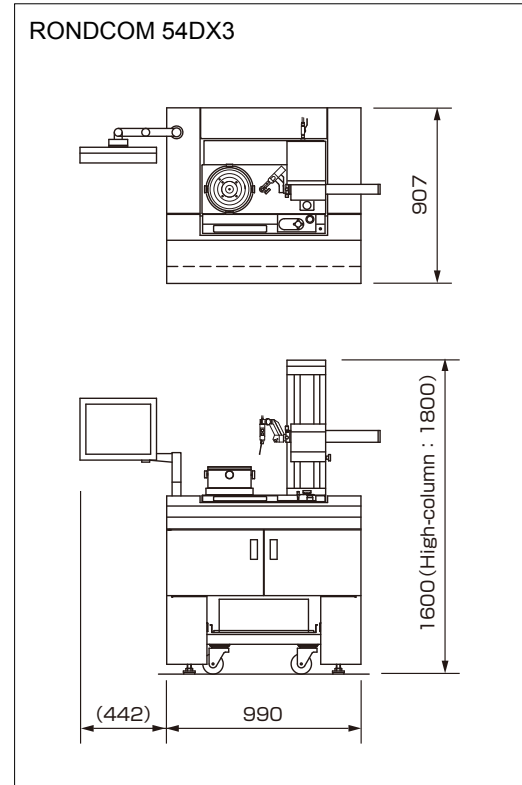

Model		RONDCOM 54DX3	
		High-column	
Measuring range	Max. measuring diameter	Outer diameter $\phi 300\text{mm}$, Inner diameter $\phi 360\text{mm}$	
	Left/right feed (R-axis)	180mm	
	Up/down feed (Z-axis)	300mm	500mm
	Max. load diameter	$\phi 580\text{mm}$	
	Max. measuring height	Outer diameter 300mm Inner diameter 300mm	Outer diameter 500mm Inner diameter 500mm
	Max. measuring depth(Inside height)	150mm *	
Rotation accuracy	Radius direction JIS B 7451-1997	$(0.02+3.7H/10,000)\mu\text{m}$ (H:Height from table surface to measuring point mm)	
	Axial direction JIS B 7451-1997	$(0.02+3.7R/10,000)\mu\text{m}$ (R:Distance from table center of rotation mm)	
Straightness accuracy	Up/down direction (Z-axis)	0.11 $\mu\text{m}/100\text{mm}$ 0.17 $\mu\text{m}/290\text{mm}$	0.11 $\mu\text{m}/100\text{mm}$ 0.23 $\mu\text{m}/490\text{mm}$
	Radius direction (R-axis)	0.7 $\mu\text{m}/150\text{mm}$	
Parallelism accuracy	Up/down direction (Z-axis)	0.7 $\mu\text{m}/290\text{mm}$	1.04 $\mu\text{m}/490\text{mm}$
	Radius direction (R-axis)	1.0 $\mu\text{m}/150\text{mm}$	
Indication accuracy	Radius direction (R-axis)	$(2+L/180)\mu\text{m}$ L:Driving distance (mm)	
Measuring speed	Rotation speed (θ -axis)	2~10/min (Driving speed:Max 20/min)	
	Up/down speed (Z-axis)	0.5~6mm/s (Driving speed:Max 50mm/s)	
	Radius speed (R-axis)	0.5~6mm/s (Driving speed:Max 25mm/s)	
Measuring range		$\pm 1000\mu\text{m}$, $\pm 200\mu\text{m}$	
Dimensions and weight	Power source(voltage specification required)	Single phase:AC100~240V, 50/60Hz:grounding required	
	Air source	Supply pressure:0.35~0.7MPa, Usage pressure:0.3MPa	
	Air consumption	30NL/min	
	Dimensions(W×D×Hmm)	990×925×1600	990×925×1800
	Weight(kg)	500	510

* (There is restriction depending on the combination with stylus length, detectors and measuring diameter.)

RONDCOM 54SD3

Flexible Separate Type to Install

This manual machine delivers superior cost performance by the combination with options.

- Compact, High-accuracy CNC Roundness Measuring Machine
- Rotation accuracy $0.02+3.7H/10,000\mu\text{m}$
- Integrated Analysis Software ACCTee



RONDCOM 54SD3

(Anti-vibration table, system rack and printer are options.)

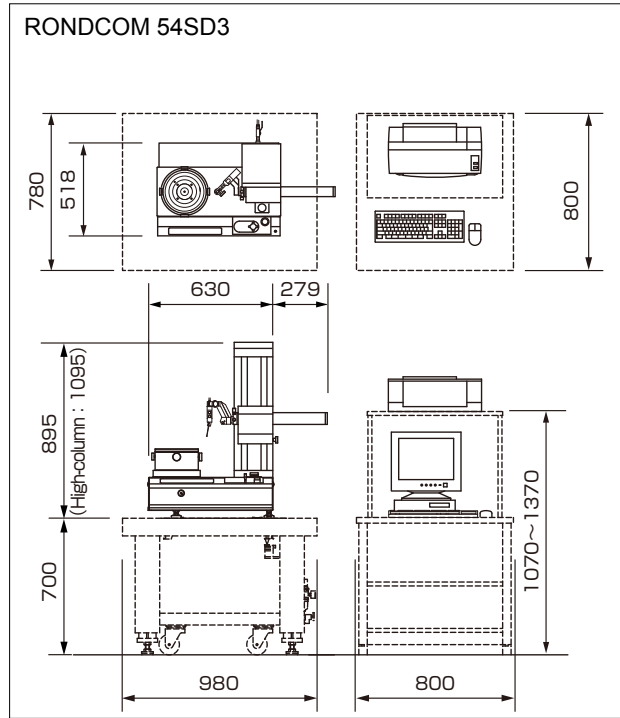

Option Anti-vibration table:E-VS-R16A(H=700)
System Rack:E-DK-S24A

Model		RONDCOM 54SD3	
		High-column	
Measuring range	Max. measuring diameter	Outer diameter $\phi 300\text{mm}$, Inner diameter $\phi 360\text{mm}$	
	Left/right feed (R-axis)	180mm	
	Up/down feed (Z-axis)	300mm	500mm
	Max. load diameter	$\phi 580\text{mm}$	
	Max. measuring height	Outer diameter 300mm Inner diameter 300mm	Outer diameter 500mm Inner diameter 500mm
	Max. measuring depth(Inside height)	150mm *	
Rotation accuracy	Radius direction JIS B 7451-1997	$(0.02+3.7H/10,000) \mu\text{m}$ (H:Height from table surface to measuring point mm)	
	Axial direction JIS B 7451-1997	$(0.02+3.7R/10,000) \mu\text{m}$ (R:Distance from table center of rotation mm)	
Straightness accuracy	Up/down direction (Z-axis)	0.11 $\mu\text{m}/100\text{mm}$ 0.17 $\mu\text{m}/290\text{mm}$	0.11 $\mu\text{m}/100\text{mm}$ 0.23 $\mu\text{m}/490\text{mm}$
	Radius direction (R-axis)	0.7 $\mu\text{m}/150\text{mm}$	
Parallelism accuracy	Up/down direction (Z-axis)	0.7 $\mu\text{m}/290\text{mm}$	1.04 $\mu\text{m}/490\text{mm}$
	Radius direction (R-axis)	1.0 $\mu\text{m}/150\text{mm}$	
Indication accuracy	Radius direction (R-axis)	$(2+L/180) \mu\text{m}$ L:Driving distance(mm)	
Measuring speed	Rotation speed (θ -axis)	2~10/min (Driving speed:Max 20/min)	
	Up/down speed (Z-axis)	0.5~6mm/s (Driving speed:Max 50mm/s)	
	Radius speed (R-axis)	0.5~6mm/s (Driving speed:Max 25mm/s)	
Measuring range		$\pm 1000\mu\text{m}$, $\pm 200\mu\text{m}$	
Dimensions and weight	Power source(voltage specification required)	Single phase:AC100~240V, 50/60Hz:grounding required	
	Air source	Supply pressure:0.35~0.7MPa, Usage pressure:0.3MPa	
	Air consumption	30NL/min	
	Dimensions(W×D×Hmm)	630×518×895	630×518×1095
	Weight(kg)	200	210

* (There is restriction depending on the combination with stylus length, detectors and measuring diameter.)