

NEW

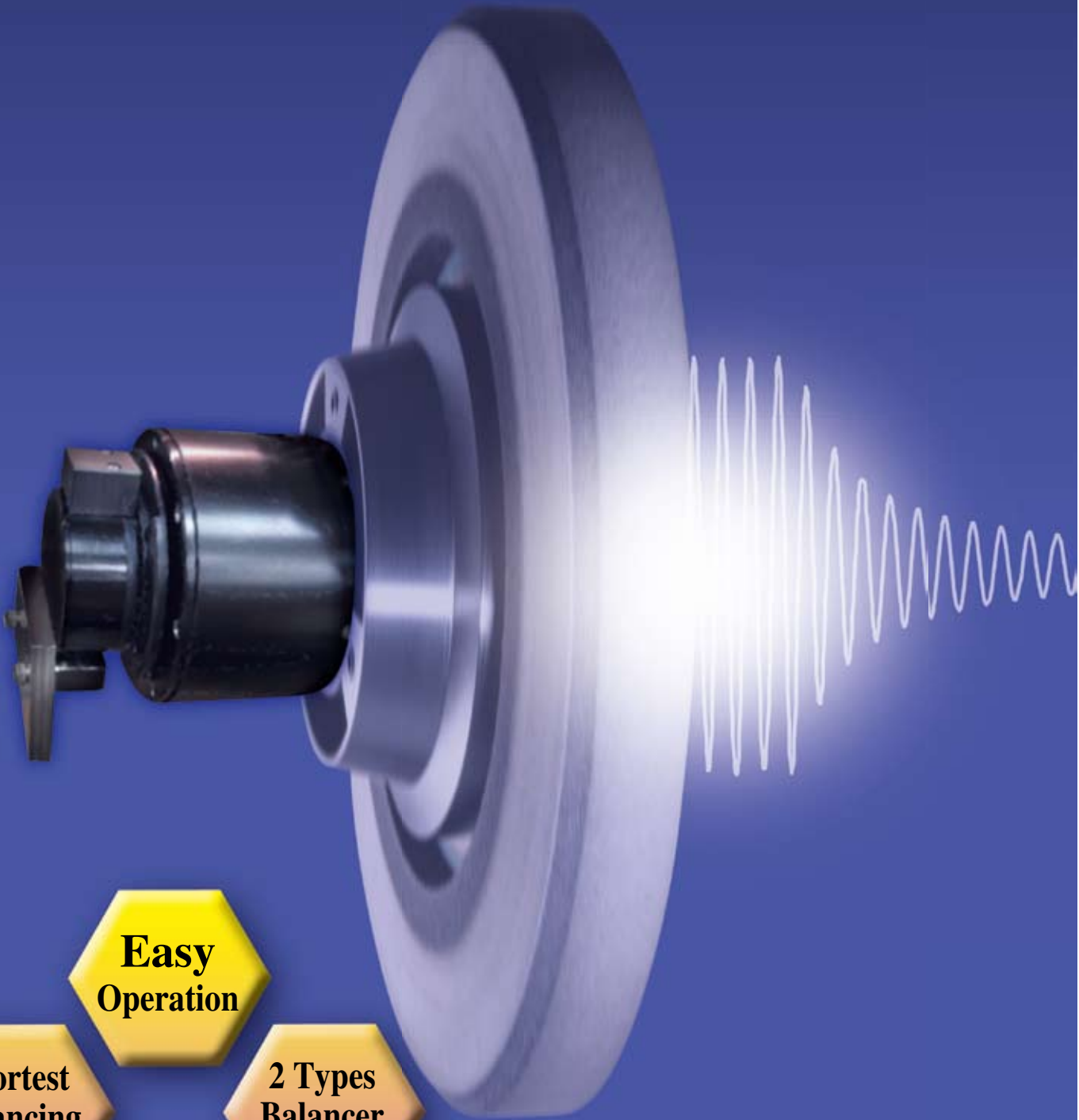

Grinding Wheel Auto Balancer

PULCOM AB-10



**Easy
Operation**

**Shortest
Balancing
Time**

**2 Types
Balancer
Head**

**DSP
Digital
Signal
Processor**

TOKYO SEIMITSU

PULCOM AB-10



Grinding Wheel Auto-balancer Advantages:

- **Reduce more than half of normal Grinding Wheel Exchange time**
(Comparison: Fully Trained Staff: 43 mins Vs Auto-balancer: 18 mins)
- **Special skill is not required to achieve ideal dynamic balance status safely and autocalically.**
(Grinding Wheel Vibration: Fully Trained Staff: 2.6 µm Vs Auto-balancer: 0.1µm)
- **Improved grinding process quality by preventing vibration**

Comparison of Grinding Wheel Exchange Process

Fully Trained Operator: 43 mins

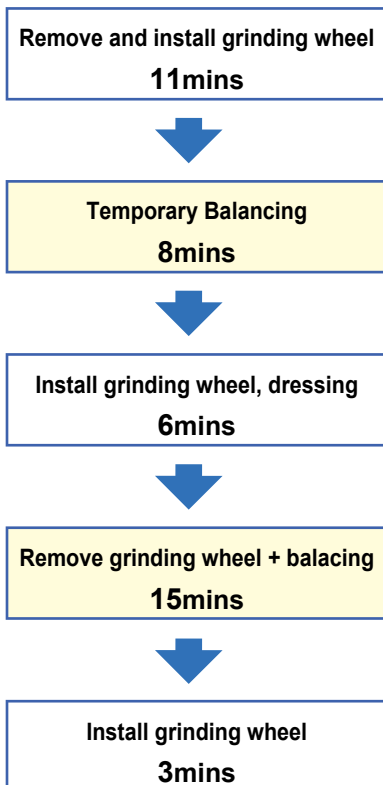

AUTO-BALANCER: 18 mins

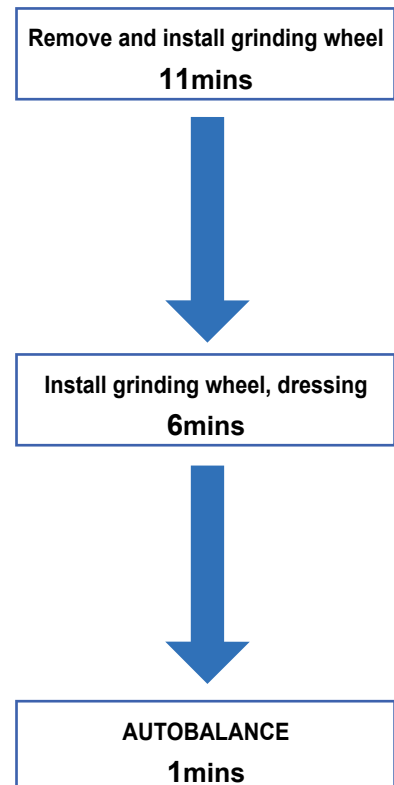

■ Improving Productivity by AB – 10

The correction of the grinding wheel balance is the key to reduce defect and labor hours in the grinding process. The less time to correct the balance was used, the more remarkable the improvement of the grinder's productivity becomes.

PULCOM AB-10 is an automatic balancing system for grinding wheels.

By using **PULCOM AB-10**, not only the grinder requires less than half of the time required by a skilled operator with 20 years of experience to change the grinding wheel; but the system also significantly reduces the vibration created by the exchange of the wheel (Skilled operator: $2.6 \mu\text{m}$ Vs Auto-balancer: $0.1 \mu\text{m}$).

In general, even for the skilled operator, it is very difficult to achieve a vibration level of less than $1 \mu\text{m}$; if a novice operator presents, the vibration and the labour hours will increase and therefore a more significant improvement could be expected should the Auto-balancer be in place.

Grinding wheel exchange time & the remaining unbalance

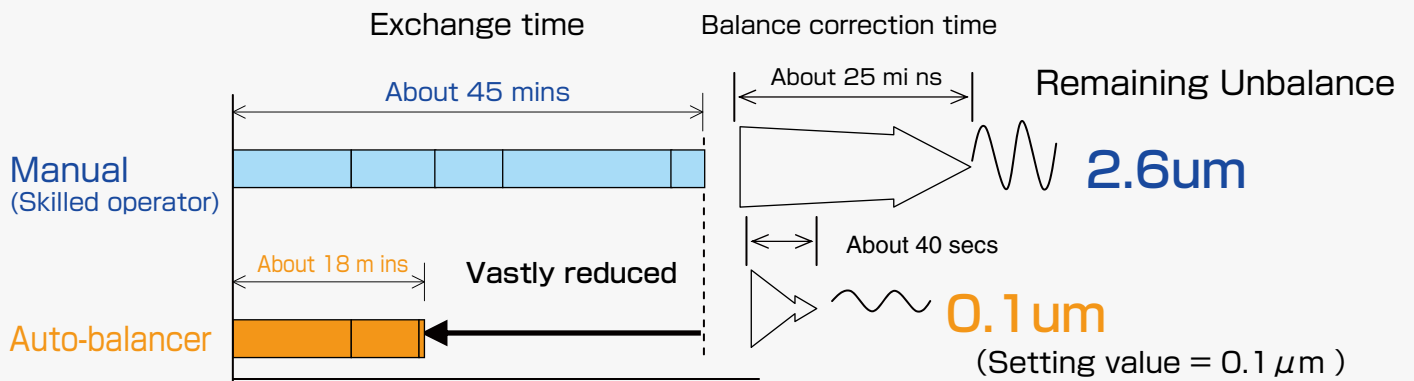

■ Easy Operation

PULCOM AB-10 will automatically correct the dynamic balance of the grinding wheel with a single button push from the front panel. (Or from the NC Command)

Now, anyone could perform perfectly, yet simply on the correction of the dynamic balance in which this complicated work could only be performed by a skilled worker previously.



① Push Button

② Balance Correcting

③ Complete

Shortest Time Balance Correction

General auto balancers correct balance by measuring vibration change caused by moving weight that is located in the balance head. In order to achieve that, weight cannot be moved fast. In some cases, when the weight moves too much, longer time may be required to correct the balance.

PULCOM AB-10 adopts high performance DSP (Digital Signal Processor), and algorithm is optimized by using Accretech's (Tokyo Seimitsu's) 3D coordinate measuring machine technology and roundness measuring machine technology. By moving weight, vibration change occurs and balance correction position can be calculated from this slight vibration change. Therefore, perfect balancing can be achieved in a short time.

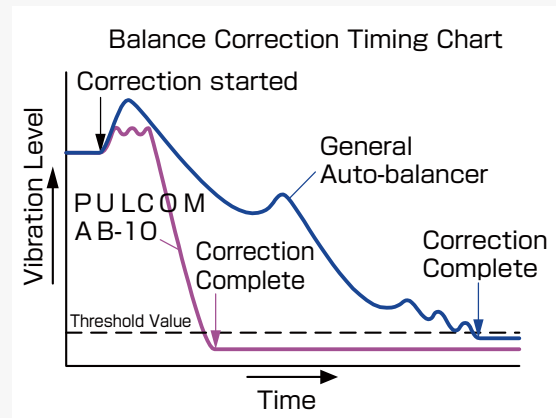

Maintaining and improving the process Quality

Poor grinding quality is caused by the vibration of the grinding table, which is caused by the unbalance of the grinding wheel. Even if balancing is performed properly at the wheel exchange time, balance may become worse by absorbing coolant or biased wear of grinding wheel.

PULCOM AB-10 observes vibration of grinding table, and if the vibration level becomes more than the threshold setting value, signal will be sent to NC to notify the operator that balancing is needed.

This system prevents producing defects caused by unbalance of grinding wheel.

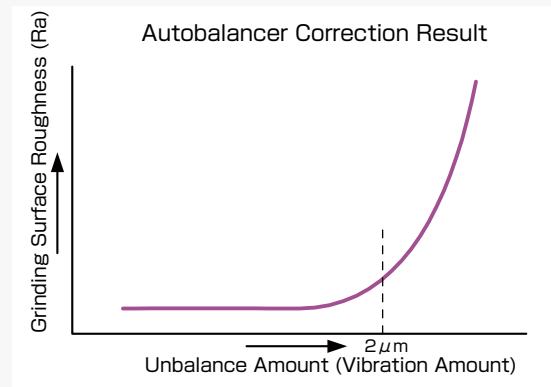

2 Types of Balance Head

There are 2 types of balance head that have different power supply methods.

Brush type Balance Head (Installed into grinder wheel side)

This type of balance head is appropriate if vibration sensor and controller are installed only while balancing is being performed. Balance head is installed into the flange of grinding wheel. It is possible to achieve more accurate balancing because it is performed at a very close position to the grinding wheel. The cable of the balance head can be removed from the head side, so balance head does not need to be removed while the grinder wheel was being exchanged.

Non-contact type balance head (Installed into pulley side)

This type of balance head is appropriate if balance head needs to be installed at all time to observe vibration and to do balancing. There are no restrictions about grinder space because it is installed at the opposite side of the grinding wheel. Power is supplied to balance head by non-contact method, therefore it has a long life time. Generally this type of balance head is used for many of cylindrical grinding machines.

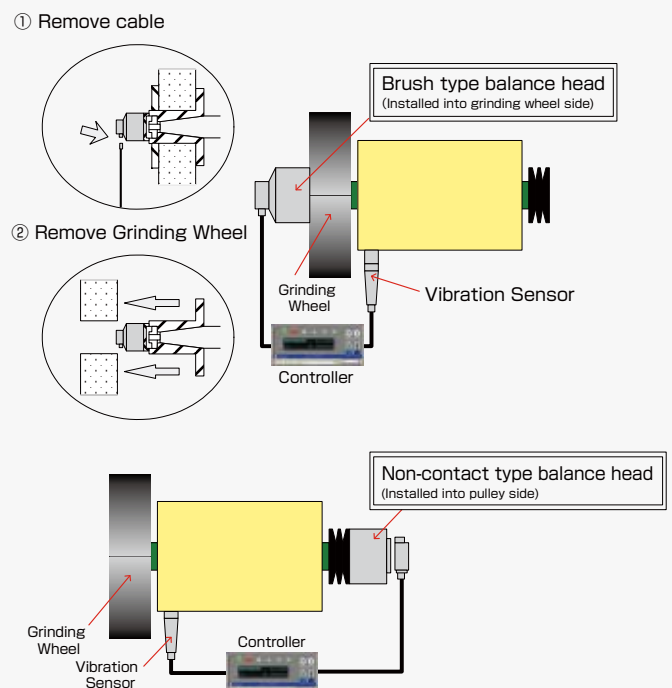

■ System Configuration

■ NON-CONTACT TYPE BALANCE HEAD SYSTEM

Non-contact type balance head

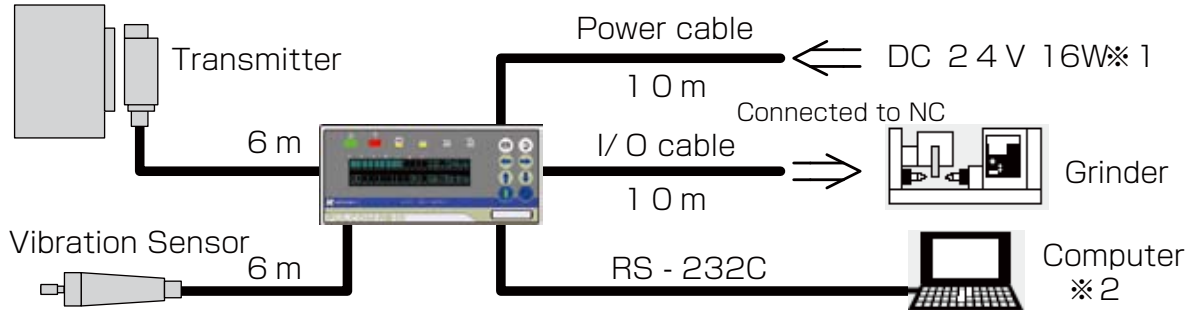

■ BRUSH TYPE BALANCE HEAD SYSTEM

Brush type balance head

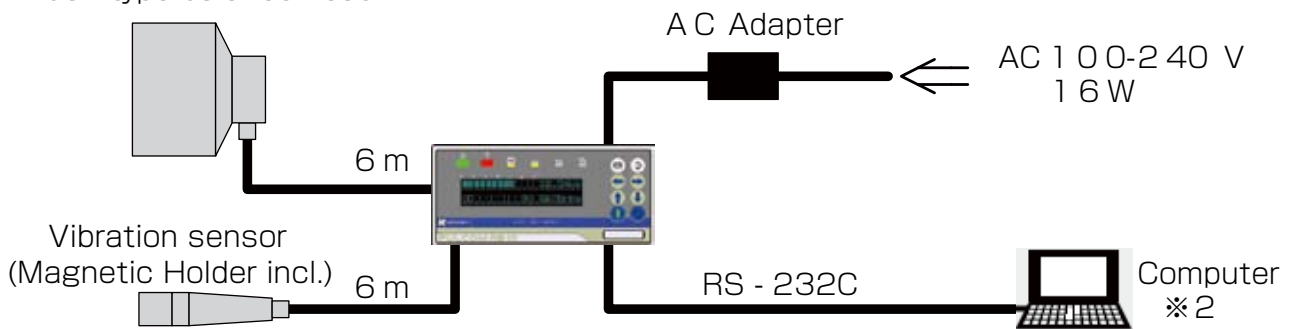

※1 Please dedicate one DC-24V power supply source to the controller

※2 Computer is not required on normal operation and should be used only during maintenance.

Basic Specifications

Controller

NAME	FOR NON-CONTACT TYPE BALANCE HEAD	FOR BRUSH TYPE BALANCE HEAD
PRODUCT CODE	0963511	0936519
MODEL	BH-6511	BH-6519
DISPLAY METHOD	Flourescent Display Tube + LED	
VIBRATION RESOLUTION	0.01 μ m	
POWER RATED	DC24V \pm 10% 16W	AC100~240V 16W (AC Adapter)
ANALOG OUTPUT	0~+5V Output impedance - 1 k	
IO INPUT	Photocoupler input -10mA max	
IO OUTPUT	Open drain output (sink/source) 24VDC 40mA max	
CE MARKING	Standard	
USAGE ENVIRONMENT	Temperature: 0~80 Humidity:10~90%RH	
WATERPROOF	IP54 (Front Panel Only)	

Vibration Sensor

NAME	FOR NON-CONTACT TYPE BALANCE HEAD	FOR BRUSH TYPE BALANCE HEAD
PRODUCT CODE	0936513	
MODEL	BH6513	
INSTALLATION METHOD	M6Bolt (Magnet is Optional)	M6Bolt or Magnet (Magnet Included)
MAX ROTATION SPEED	10,000rpm	
CABLE LENGTH	6m	
USAGE ENVIRONMENT	Temperature: 0~50 Humidity:10~90%RH	
WATERPROOF	IP67	

Balance Head

NAME	FOR NON-CONTACT TYPE BALANCE HEAD	FOR BRUSH TYPE BALANCE HEAD
PRODUCT CODE/ MODEL	Please refer to the table of the product code.	
BALANCING VOLUME / ROTATION SPEED	2000gcm/3000rpm 1300gcm/4000rpm 900gcm/4000rpm 400gcm/6000rpm	
BALANCE HEAD TYPE	Flange type	
POWER SUPPLY TYPE	Non-contact type	Brush type
POWER SUPPLY GAP	2~3mm	-
BRUSH LIFE SPAN	-	3000hours@3000rpm
CABLE LENGTH	6m	6m (Possible to be removed)
USAGE ENVIRONMENT	Temperature:0~50 Humidity:10~90%RH	
WATERPROOF	IP67	

Model dimensions

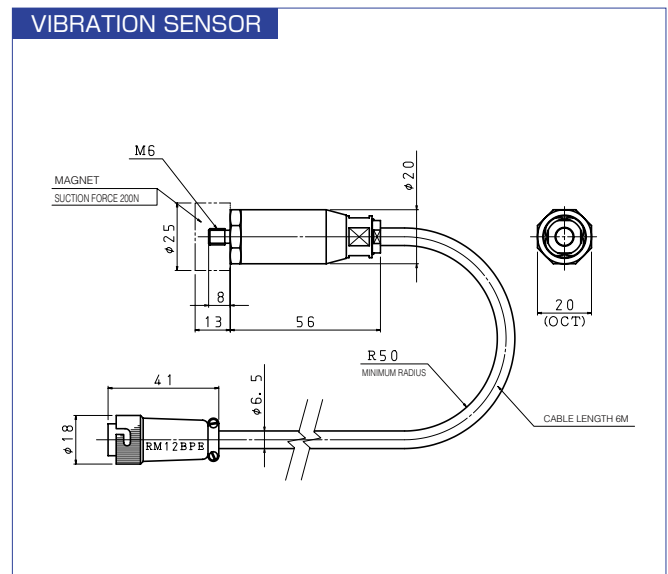
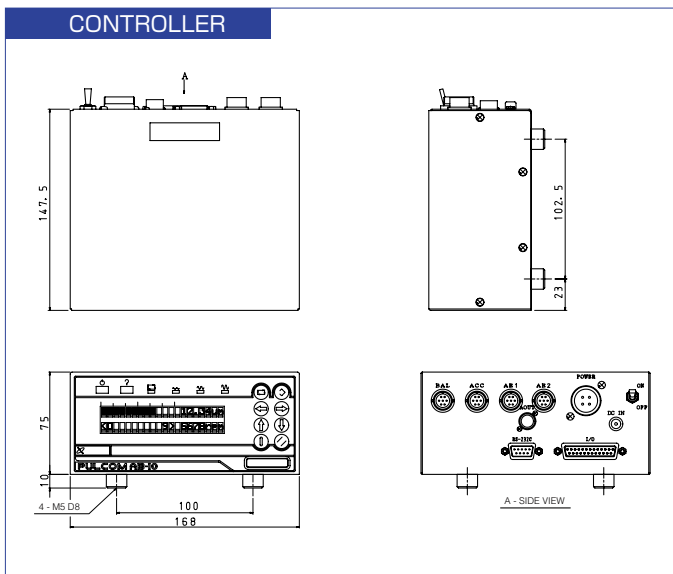

Product Code

System

PRODUCT CODE	PRODUCT NAME	SPECIFICATION / ACCESSORIES ETC.
0963510	PULCOM AB-10 Non-contact type balance head system	Controller (Non-contact type, 24VDC input), Vibration sensor, non-contact balance head(※), transmitter, power, cable, IO cable.
0963540	PULCOM AB-10 Brush type balance head system	Controller (Brush type, AC input), Vibration sensor, Magnet used by the vibration sensor, brush type balance head (※), AC adapter, Balance head cable.

※Please select the correct balance head with the appropriate balancing volume and the max rotation speed from the table below:

Balance Head

Balance Head	MODEL	SPECIFICATION (BALANCING VOLUME / MAX ROTATION SPEED)
NON-CONTACT TYPE BALANCE HEAD		
0936521	BH-E6521	2000gcm / 3000rpm
0936524	BH-E6524	1300gcm / 4000rpm
0936527	BH-E6527	900gcm / 4000rpm
0936571	BH-E6571	400gcm / 6000rpm
BRUSH TYPE BALANCE HEAD		
0936523	BH-B6523	2000gcm / 3000rpm
0936526	BH-B6526	1300gcm / 4000rpm
0936529	BH-B6529	900gcm / 4000rpm
0936573	BH-B6573	400gcm / 6000rpm

Option

PRODUCT CODE	PRODUCT NAME	SPECIFICATION / MODEL
0936514	Magnet for vibration sensor	BH-6514
0936532	Extension cable for vibration sensor	6m
0936212	Analog output cable	6m
0936531	Extension cable for transmitter	6m
0936535	Extension cable for brush type balance head	6m

BALANCE HEAD

NON-CONTACT TYPE

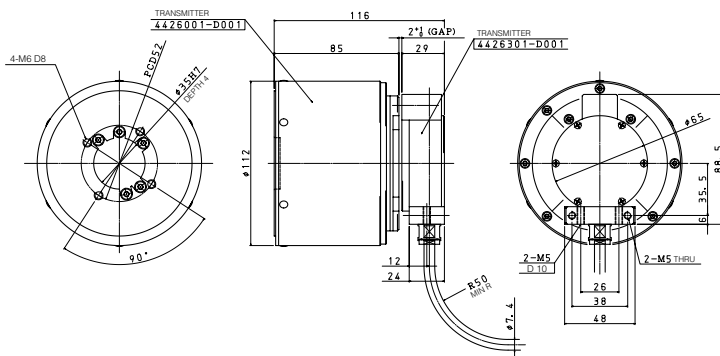

BRUSH TYPE

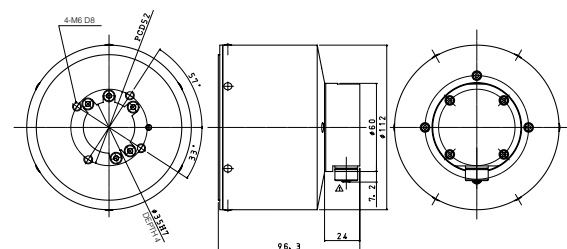

Please contact the following branch to order :

TOKYO SEIMITSU



JAPAN

TOKYO SEIMITSU Co., LTD
81-29-831-1240

USA

Tokyo Seimitsu USA Branch
1-248-332-0100 (Michigan)

EU

ACCRETECH EUROPE GmbH
49-89/546788-0

Technical support
TOSEI ENGINEERING Co.,LTD
FAX : 81-298-30-1891
E-mail : amg@toseieng.co.jp

TSE-462-E-1002